



Model 400i

Recirculating fume extraction is now extremely important with the rising concern for our environment and employee safety. Purex Fume Extractors provide not only a flexible and portable process for plant redesigns and expansions, but also a more stable process by providing a controlled airflow to remove harmful fumes. All this while eliminating the added costs of building modifications, increased air handling systems and lost energy.

## Purex Digital Systems

- ❖ Automatic Flow Control maintains constant extraction rate
- ❖ Adjustable Air Flow extends filter life
- ❖ Blocked Filter Warning
- ❖ Easy to change filters
- ❖ Low energy consumption
- ❖ Quiet operation
- ❖ Welded stainless steel construction
- ❖ Reverse Air Flow prevents condensation and extends filter life
- ❖ Continuous run brushless motors
- ❖ HEPA filtration removes 99.997% of particles down to .3 microns
- ❖ Gas and particle sensors on exhaust
- ❖ Filter Blocked Monitor
- ❖ Gas Safety Sensor
- ❖ Particle Safety Sensor
- ❖ Motor Run Indicator
- ❖ Airflow reading
- ❖ Filtered air temperature
- ❖ Quick-read visual display
- ❖ Remote Machine Interface

# 400i Volume Control

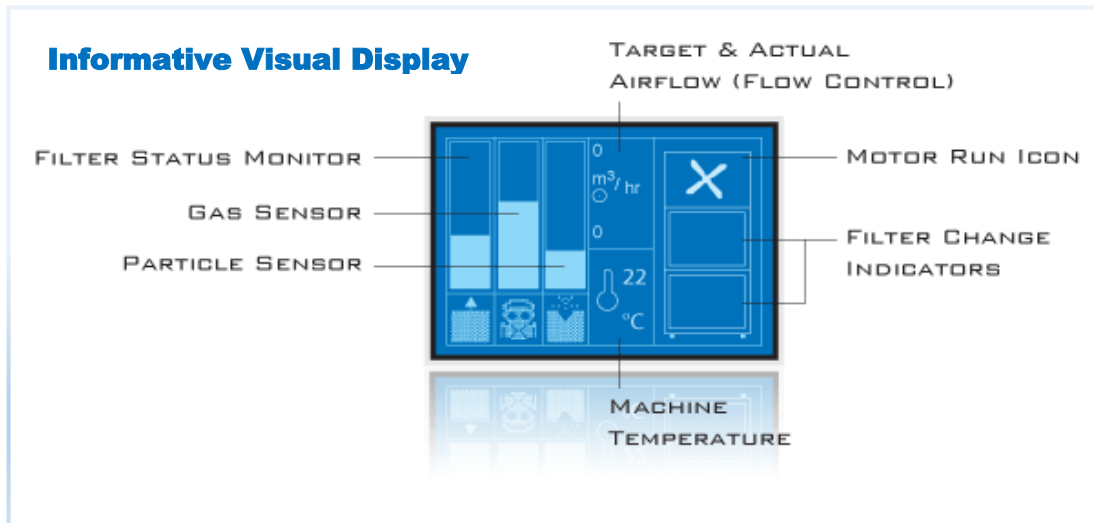

Main Filter Options		
	HEPA/Chemical	113505
	HEPA/Twin Chemical	113579
	HEPA Chemical Cleanroom*	113512
	Chemical	113508
*Use F8/F9 Pre-filter		

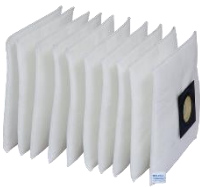
Labyrinth Pre-Filter Options		
	F6 (std) 60-80% eff 1-3µ	202268
	F8/F9 Composite >95% eff .5-1 µ	202271

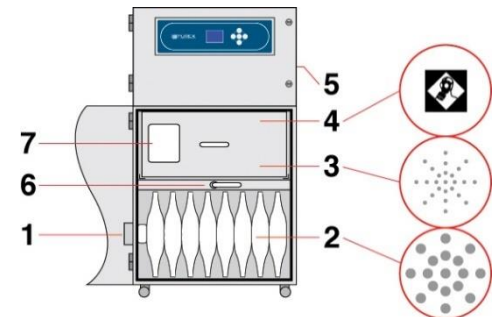

- 1) Air inlet
- 2) Pre-filter
- 3) Main filter (HEPA)
- 4) Main filter (Carbon)
- 5) Clean air return
- 6) Filter lock Handle
- 7) Filter I.D. label

	400i	
Model	0LX4013D	0LX4010D
Voltage (50hz/60Hz)	120v (1ph)	230v (1ph)
Wattage	1.37 kW	1.30 kW
Airflow	275 cfm (467 m <sup>3</sup> /Hr)	
Vacuum	40 inwg (9.92 kPa)	
Air Inlet	3.14in (80mm) Safe Seal	
Sound Rating	52 dBA	
Dimensions (L/W/H)	18.3in x 21in x 42.25in	
Weight	132 lbs	